

# ET-3 Elevating Table

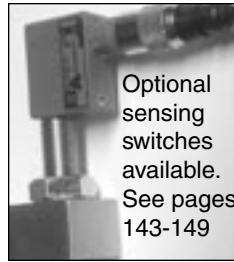

Optional sensing switches available. See pages 143-149

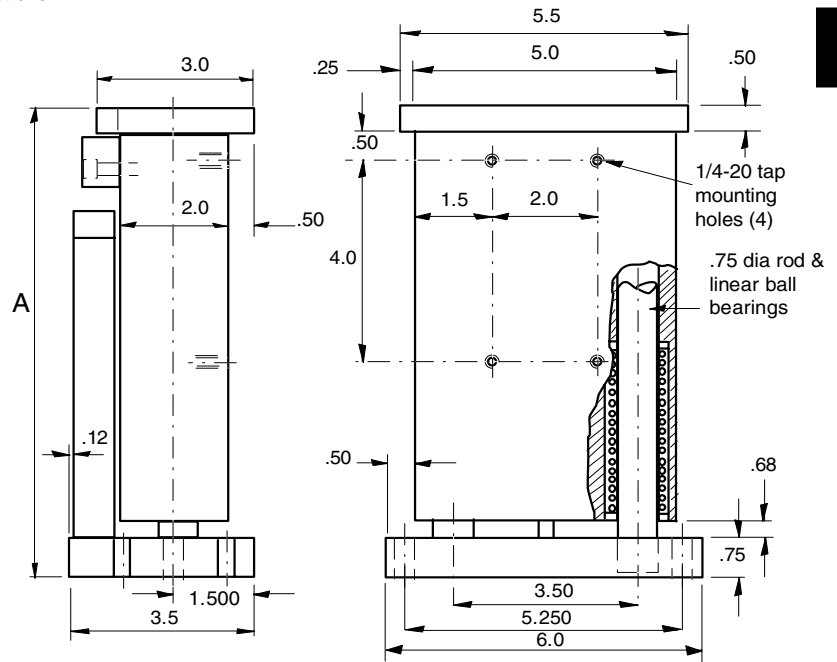
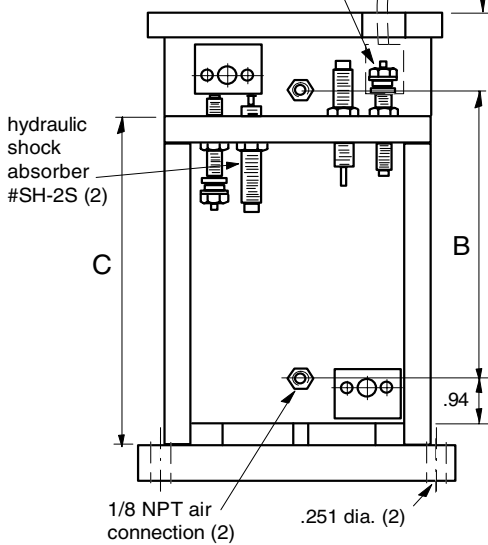
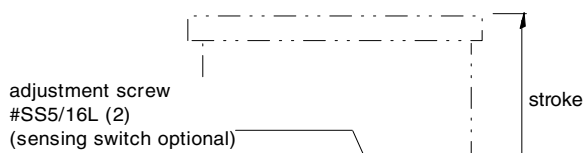
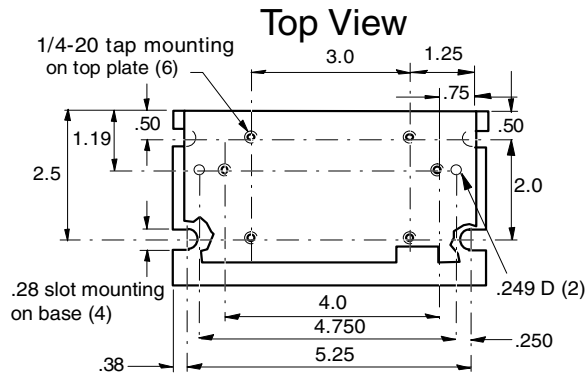

Type	Stroke	A	B	C	Force @ 80psi	Weight
ET-3-2	0-2"	7.69	3.75	4.75	60 lbs	12 lbs
ET-3-4	0-4"	9.69	5.75	6.75	60 lbs	16 lbs

## Technical data

- 1 1/8" Bore
- Stroke designed with built in stopscrews with fine threads.
- The stopscrews can be used with sensing switches.
- Designed for production rates and long life.
- Seal kits and rebuild kits available.

Operating medium  
Operating pressure  
Repeat accuracy  
Air connection

Compressed air or hydraulic oil  
60-100 psi  
±0.0005 in  
1/8 NPT