

LA-2 Linear Actuator

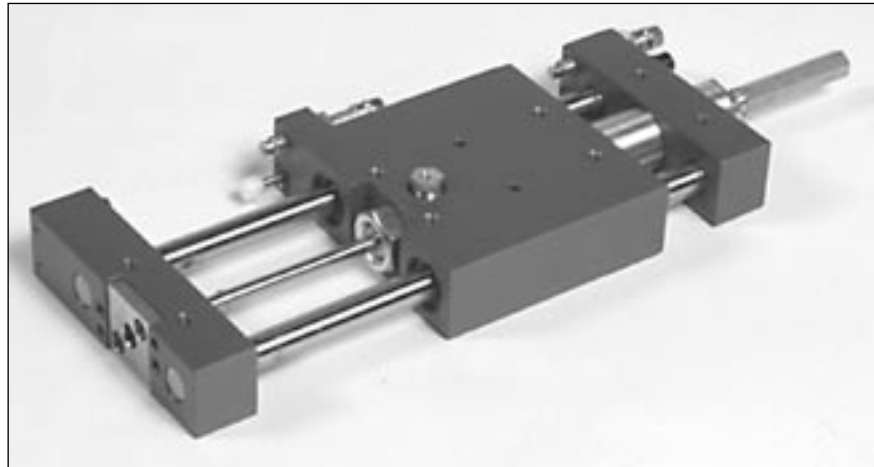

Features

- 3/4" bore
- 0.500" dia. case hardened & ground shafts
- 4 linear ball bearings and seals
- Cylinders can be rebuilt
- Chrome plated cylinder rods
- Adjustable stopscrews for end of stroke adjustment
- Sensing switches can be used with stopscrews
- Compressed air from 60-100 psi
- 10-32 air connection
- Tapped & dowel pin holes in anodized body for ease of mounting



- End blocks anodized and include tapped & dowel pin holes
- Hydraulic shock absorbers

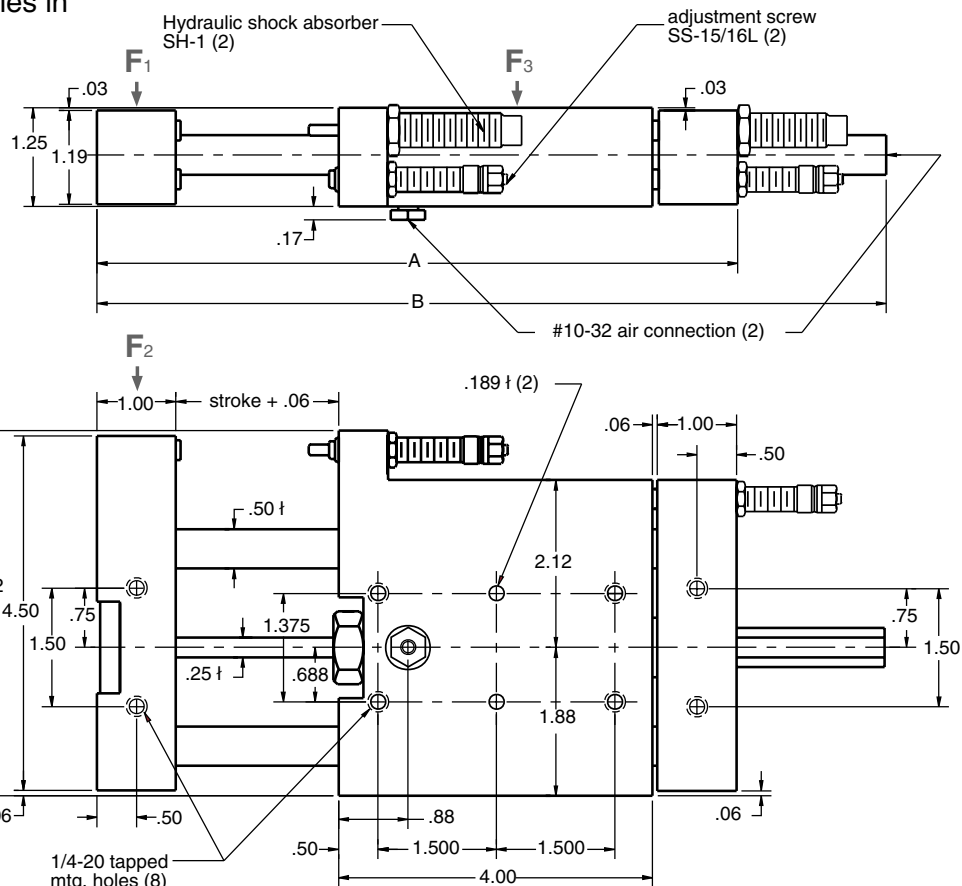

Ordering

The LA-2 comes in four standard stroke lengths: # = 2, 4, 6, & 8. Custom stroke lengths are available upon request.

LA-2-# - CR for Clean Room option

Type	Stroke	A	B	Weight
LA-2-2	2"	8.12	10.0	4.0
LA-2-4	4"	10.12	14.0	4.5
LA-2-6	6"	12.12	18.0	5.0
LA-2-8	8"	14.12	22.0	5.5

LA-2 Linear Actuator

Applications

LA-2 mounted vertically to a TSHD-3 Heavy Duty Table Slide. A B-2S Gripper is mounted to the end of the slide. This configuration represents a TSL-32 Combined Motion Unit.



Two LA-2-4 actuators mounted to each other for a 4 position pick-up and drop-off application.

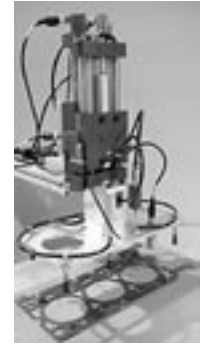

Technical Data

Force @ 80 psi = 32 lbs
 Repeat accuracy = +/-0.0005"
 Life expectancy = >100 million travel inches

Force diagrams below depict the load (F#) and the resultant deflection (y#) caused by that force (or torque T).

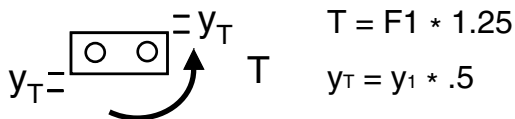
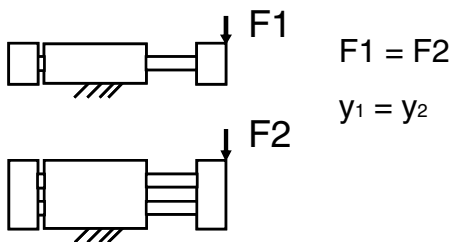

F1 Load vs. Travel at set Deflections for the LA-2

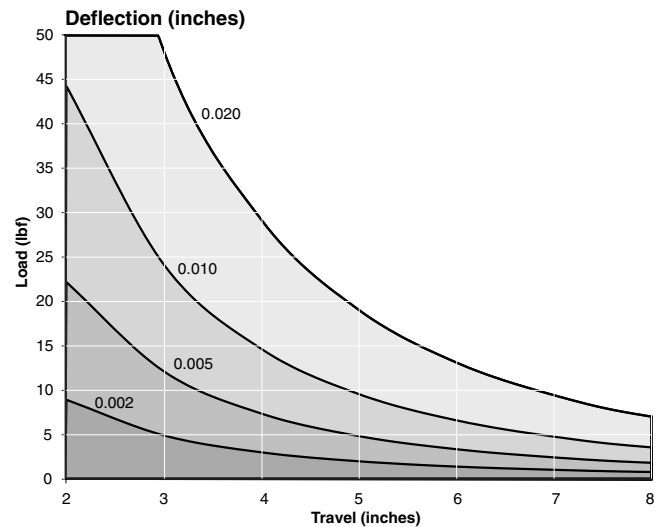

Life(millions of inches traveled) vs. Travel & Load

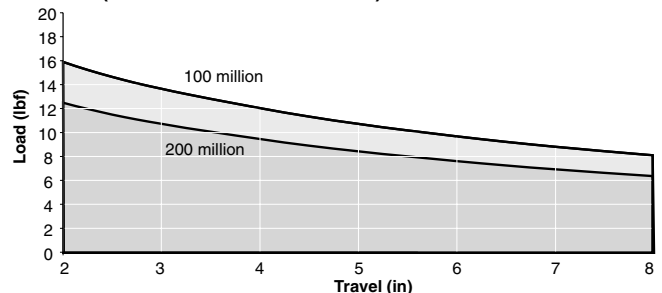

Options

Sensing switches are available as an option. They are mounted to the stopscrews as seen in the photo to the right. For specifications on sensing please see page 143.

For clean room applications the LA-2 is available with stainless steel guide rods,

stainless steel hardware, non-lube sleeve-type bushings, and nickel-plated stopscrews and shock absorbers.

