

FLAIRLINE
FAST
Shipped in 3-5 days



THE LIGHT-WEIGHT
LINE WITH
HEAVY-DUTY
FEATURES

POWERED SLIDES	2	SPECIAL OPTIONS	6
DIMENSIONAL DATA	3	SPECIAL OPTIONS	7
ENGINEERING DATA	4	ORDERING INSTRUCTIONS	8
ENGINEERING DATA	5		

**FLAIRLINE®
POWERED SLIDES**

A FLAIR FOR RELIABILITY, AVAILABILITY,
ECONOMY AND SERVICE

Hi-Cycle Means Value

You can select Flairline products with confidence. They are expertly designed, made of the finest materials available, and carefully assembled. Anodized aluminum construction for light weight and quality seals for reliability combine to give you outstanding product performance. Our design specifications are precisely held during manufacture, and every individual product must pass stringent functional tests before they are considered "customer ready."

After testing is completed, **Flairline/Fast shipping** assures that Flairline products are shipped to our distributors or directly to the customers within three to five working days. Flairline understands that availability is important.

So is price. Flairline products are surprisingly inexpensive, rapidly repaying your low initial investment with trouble-free operation. Quality design and easy repairability enhance production and add value to your equipment.

Should Flairline products need service, we provide that, too. Our interest in your complete satisfaction doesn't end

after the sale. With repair kits and parts, Flairline is prepared to handle any emergency and minimize downtime.

Make your selections with complete confidence from our extensive line of low cost, fast-action pneumatic or hydraulic actuators.

Special Products

Flairline standard products offer a wide variety of application capabilities. No matter how extensive a product line may be, there is often a need for something unique for your special application. Responding to this need is important to Flairline. We are pleased to offer our capabilities to manufacture pneumatic and hydraulic actuators to your specifications.

Contact your local Flairline distributor for more information.

CAD Files on Disk

CAD product drawings are available in DXF or DWG formats for use with this catalog. These drawings can also be downloaded from our Web site at **www.flairline.com**

POWERED SLIDES

FLAIRLINE HI-CYCLE
SERIES OPS AND MPS

Flairline Series OPS and MPS powered slides feature four guide-rod bearings consisting of a material based on a tough thermoplastic alloy, a matrix of highly abrasion-resistant fibers and a friction-reducing solid lubricant mix. Special characteristics of the guide rod bearings include: wear resistance, low coefficient of friction, vibration dampening properties, dirt resistance and high resistance to chemicals. All powered slides have oversized chrome-plated, high-strength, corrosion resistant steel guide-rods. Series OPS and MPS are powered by Flairline cylinders featuring dynamic O-ring piston seals (Buna N standard; Viton available). Construction of Flairline "repairable" powered slide cylinders includes stainless steel piston rods (chrome-plated steel on 1-1/2" bore models), aluminum heads and caps, hard-anodized aluminum barrels and anodized aluminum bodies and tool blocks. See pages 4 and 5 for engineering data and pages 6 and 7 for special options.

For automated stroke sequencing, specify Series MPS powered slides. Series MPS models are powered by Flairline magnetic switch cylinders which include pistons with factory installed magnets. Magnetic switch options include Reed and Hall Effect types. Stainless steel mounting bands can be adjusted to any location on the cylinder allowing several switches to be mounted for controlling or initiating any sequence function. See Flairline "Cylinders and Valves" catalog for additional information on switch options. See pages 4 and 5 for engineering data and pages 6 and 7 for special options.

For ordering information, see page 8

OPS/MPS

Standard Bore Sizes – 1/2, 3/4, 1¹/_s, 1¹/₂

Stock Stroke Sizes – See Ordering Instructions on page 8.

Internal cushions available – both ends of powered slide cylinder

Pneumatic – 200 psi maximum

Hydraulic – 200 psi maximum

DIMENSIONAL DATA

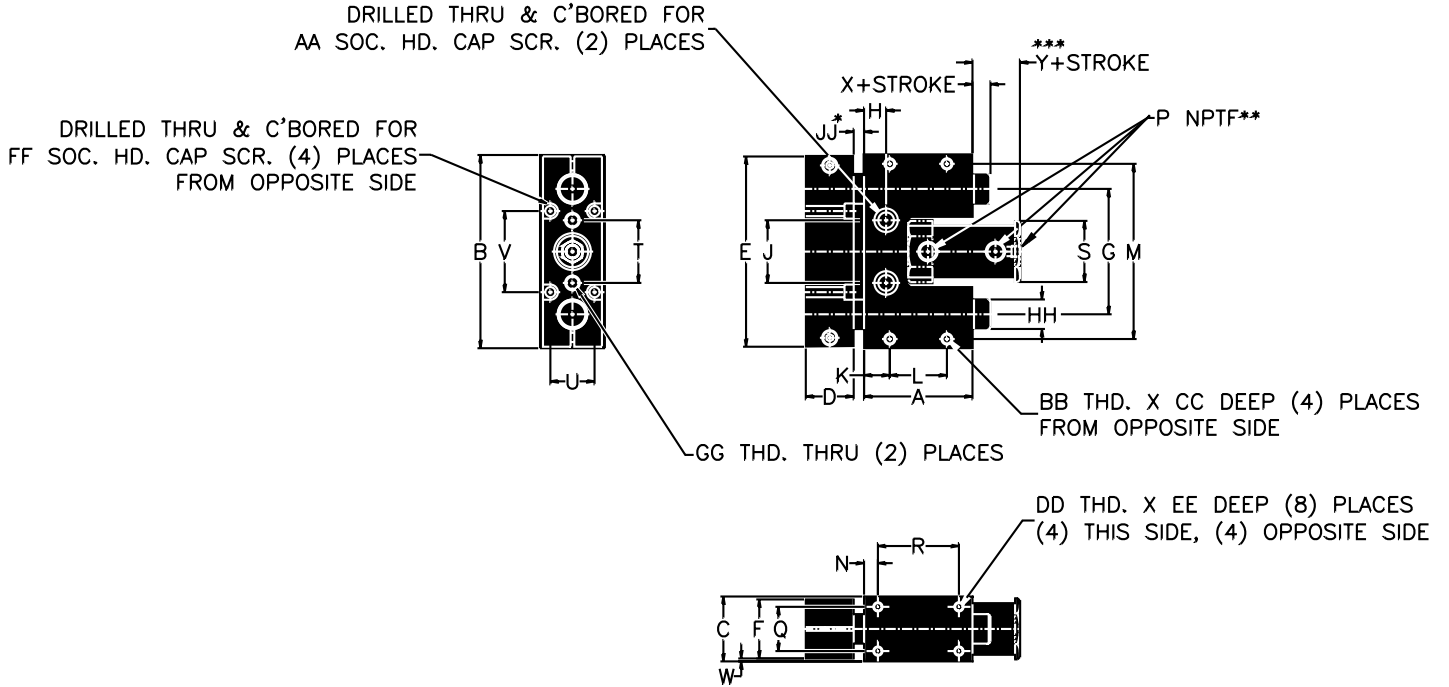

*Dimension "JJ" (tool block extension - distance between the tool block and the body) is normally "0". On powered slides with internal cushions (Option "HC"), dimension "JJ" is 1/8". To order Special Dimension "JJ", see page 7 for special options and page 8 for ordering instructions.

**On 1/2, 3/4 and 1 1/8 bore powered slides, the cap-end port is located in the center of the cap.

***On 1/2, 3/4, and 1 1/8 bore powered slides with internal cushions (Option "HC"), dimension "Y" increases by 1". In addition, dimension "Y" will increase by 1" for 1/2, 3/4 and 1-1/8 bore powered slides series MPS.

DIMENSION REFERENCE	CYLINDER BORE				DIMENSION REFERENCE	CYLINDER BORE			
	1/2	3/4	1 1/8	1 1/2		1/2	3/4	1 1/8	1 1/2
A	2 1/4	2 25/64	3 17/64	3 11/16	S	7/8	1 5/32	1 19/32	1 3/4
B	3 1/4	3 7/8	5 1/2	6 35/64	T	1 1/8	1 5/16	1 13/16	2 1/8
C	1 1/8	1 1/4	1 45/64	2 13/64	U	11/16	25/32	1 1/8	1 1/2
D	5/8	7/8	1 1/4	1 5/8	V	1 9/16	1 5/8	2 13/32	2 3/4
E	3 1/8	3 13/16	5 3/8	6 29/64	W	1/16	1/16	1/10	1/10
F	1	1 1/8	1 1/2	2	X	1 5/16	1 5/16	1 9/16	1 9/16
G	2 1/8	2 5/8	3 5/8	4 1/4	Y	1/4	7/64	3/64	1 29/64
H	3/8	3/8	3/4	3/4	AA	1/4	1/4	3/8	1/2
J	1 1/8	1 5/16	1 13/16	2 1/8	BB	8-32	10-24	1/4-20	3/8-16
K	1 1/8	23/32	7/8	7/8	CC	3/8	1/2	5/8	13/16
L	3/4	15/16	1 1/2	1 15/16	DD	8-32	8-32	1/4-20	5/16-18
M	1 3/8	3 9/16	5	5 15/16	EE	3/8	3/8	1/2	5/8
N	11/32	3/8	7/16	15/32	FF	#8	#8	1/4	5/16
P	1/8-27	1/8-27	1/8-27	1/4-18	GG	1/4-20	1/4-20	3/8-16	1/2-13
Q	11/16	25/32	1 1/8	1 1/2	HH	3/8	1/2	3/4	1
R	1 9/16	1 5/8	2 13/32	2 3/4					

TABLE #1 MAXIMUM SIDE LOAD

Stroke	BORE SIZE			
	1/2	3/4	1 1/8	1 1/2
1	19.73	37.70	82.05	131.91
2	15.31	29.93	68.45	112.01
3	12.49	24.71	58.68	97.26
4	10.54	20.96	51.32	85.86
5	9.11	18.33	45.57	76.83
6	8.02	16.20	40.95	69.46
7	7.15	14.50	37.18	63.36
8	5.84	13.15	34.02	58.21
9	4.23	12.00	31.35	53.82
10	3.15	11.05	20.14	50.02
11	2.39	7.28	15.65	46.71
12	1.85	5.70	13.35	43.79
13	—	—	—	29.37
14	—	—	—	24.00
15	—	—	—	19.79
16	—	—	—	16.44
17	—	—	—	13.74
18	—	—	—	13.63

TABLE #2 MAXIMUM MOMENTS (INCH LBS.)

Stroke	BORE SIZE			
	1/2	3/4	1 1/8	1 1/2
1	20.97	49.48	148.71	280.30
2	16.26	39.28	124.06	238.03
3	13.27	32.43	106.35	206.68
4	11.20	27.51	93.01	182.45
5	9.68	24.06	82.60	163.26
6	8.52	21.26	74.23	147.60
7	7.60	19.04	67.38	134.65
8	6.21	17.26	61.67	123.70
9	4.50	15.76	56.83	114.38
10	3.34	14.50	36.50	106.29
11	2.54	9.56	28.36	99.26
12	1.96	7.49	24.20	93.05
13	—	—	—	62.42
14	—	—	—	51.00
15	—	—	—	42.05
16	—	—	—	34.93
17	—	—	—	29.19
18	—	—	—	28.96

TABLE #3 MAXIMUM DEFLECTION AT MAXIMUM SIDE LOAD

Stroke	BORE SIZE			
	1/2	3/4	1 1/8	1 1/2
1	.001	.001	.001	.0006
2	.003	.002	.002	.001
3	.006	.004	.003	.002
4	.009	.006	.004	.003
5	.014	.009	.006	.004
6	.019	.012	.008	.005
7	.026	.016	.010	.006
8	.030	.020	.013	.008
9	.030	.025	.015	.009
10	.030	.030	.015	.011
11	.030	.030	.015	.013
12	.030	.030	.015	.015
13	—	—	—	.015
14	—	—	—	.015
15	—	—	—	.015
16	—	—	—	.015
17	—	—	—	.015
18	—	—	—	.015

TABLE #4 DEFLECTION VS. WORK WEIGHT

Stroke	BORE SIZE			
	1/2	3/4	1 1/8	1 1/2
1	19,730	37,700	82,050	219,850
2	5,103	14,965	34,225	112,010
3	2,082	6,178	19,560	48,360
4	1,171	3,493	12,830	28,620
5	651	2,037	7,595	19,208
6	422	1,350	5,119	13,892
7	275	906	3,718	10,560
8	195	658	2,617	7,276
9	141	480	2,090	5,980
10	105	368	1,343	4,547
11	80	243	1,043	3,593
12	62	190	890	2,919
13	—	—	—	1,958
14	—	—	—	1,600
15	—	—	—	1,319
16	—	—	—	1,096
17	—	—	—	916
18	—	—	—	908

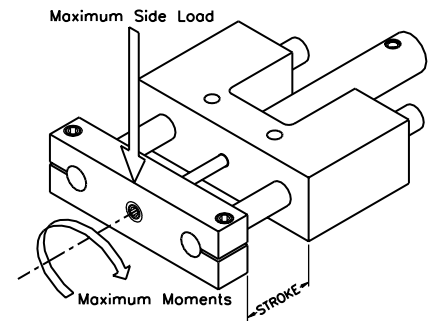

USE TABLE #4 TO CALCULATE THE WEIGHT THAT CAN BE CARRIED BY A PARTICULAR POWERED SLIDE (GIVEN BORE AND STROKE) THAT WOULD NOT DEFLECT MORE THAN A GIVEN AMOUNT. FOR EXAMPLE: WHAT WEIGHT CAN BE CARRIED BY A POWERED SLIDE (WITH A 1/2" BORE AND 18" STROKE) THAT WOULD NOT DEFLECT MORE THAN .005?
SOLUTION: (SEE TABLE #4) X .005 = 4.54 LBS

EXTERNAL BUMPERS AND STOP COLLARS OPTION

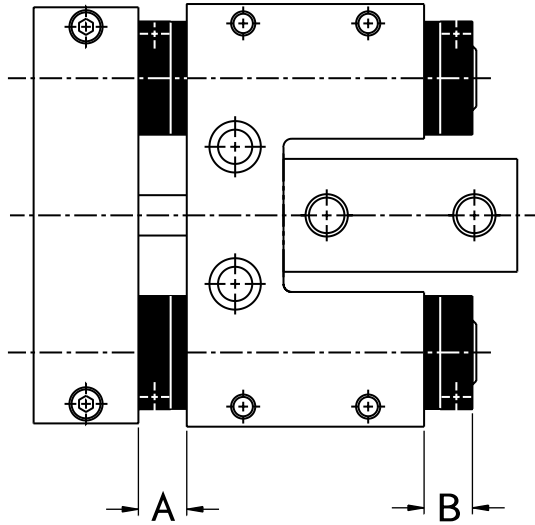

EXTERNAL URETHANE BUMPERS WITH STOP COLLARS PROVIDE STROKE ADJUSTMENT ON RETRACTION (OPTION "BR") ON EXTENSION (OPTION "BE"), OR IN BOTH DIRECTIONS (OPTION "BB"*).

NOTE: THESE OPTIONS EFFECT SOME BASIC DIMENSIONS. SEE CHART BELOW.

*Option "BB" is a combination of options "BR" and "BE."

SHOCK ABSORBER OPTION

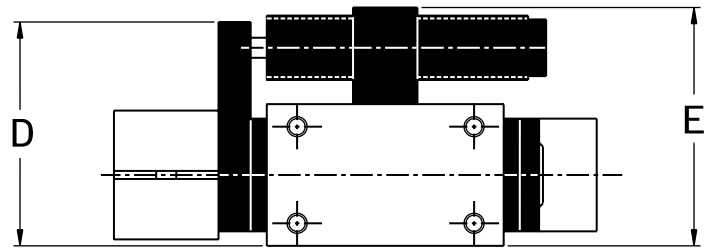
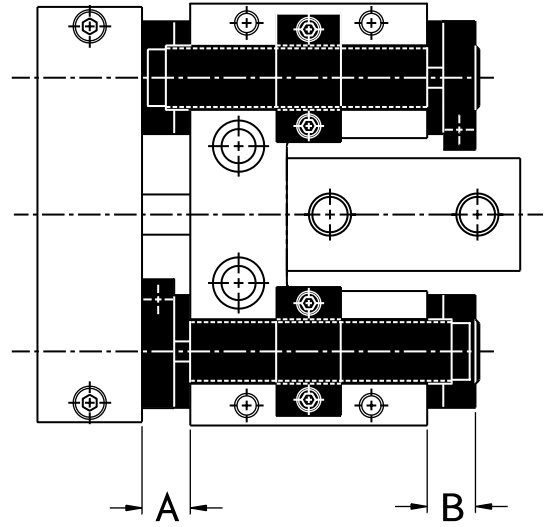

ACE CONTROLS SHOCK ABSORBERS AND EXTERNAL URETHANE BUMPERS WITH STOP COLLARS PROVIDE DECELERATION AND STROKE ADJUSTMENT ON EXTENSION (OPTION "SE"), ON RETRACTION (OPTION "SR") OR IN BOTH DIRECTIONS (OPTION "SB"*). OPTION "SE" AND "SR" EACH CONSISTS OF A SHOCK ABSORBER, MOUNTING BRACKET, STRIKER PLATE AND BUMPER ON ONE END OF THE POWERED SLIDE. A BUMPER AND STOP COLLAR ARE INCLUDED ON THE SAME END BUT MOUNTED ON THE OPPOSITE GUIDE ROD.

SEE PAGE 7 FOR SHOCK ABSORBER SELECTION.

NOTE: THESE OPTIONS EFFECT SOME BASIC DIMENSIONS. SEE CHART BELOW.

*Option "SB" is a combination of options "SR" and "SE."

OPTIONS	BR & SR		BE & SE		BB & SB		SR, SE & SB	
Bore Size	DIMENSIONS							
	A	B	A	B	A	B	D	E
1/2	5/8	0	0	5/8	5/8	5/8	2 1/8	2 1/8
3/4	5/8	0	0	5/8	5/8	5/8	2 3/16	2 1/4
1 1/8	3/4	0	0	3/4	3/4	3/4	2 63/64	3 13/64
1 1/2	3/4	0	0	3/4	3/4	3/4	3 31/64	3 45/64

SHOCK ABSORBER CALCULATION

To calculate the appropriate shock absorber:

1.) Calculate kinetic energy: $K = (.2) (W_T) (V^2)$ $W_T = W + W_B + W_A$

2.) Calculate cylinder force - for extend stroke: $F_E = (.785) (B^2) (P)$
 - for retract stroke: $F_R = (.785) (B^2 - R^2) (P)$

If slide is in a vertical position with load moving down, add W_T to cylinder force value.

3.) Calculate Propelling Force Energy - for extend stroke: $F_P = (F_E) (S)$
 - for retract stroke: $F_P = (F_R) (S)$

S = .50 for shock models 1 and 2
 S = .75 for shock models 3, 4 and 5
 S = 1.00 for shock models 6, 7 and 8

4.) Calculate energy per cycle: $E_C = K + F_P$

5.) Calculate energy per hour: $E_T = (E_C) (C)$

6.) Calculate effective weight: $W_E = \frac{E_C}{(.2) (V^2)}$

DEFINITIONS:

- F_E = cylinder force on extension (lbs.)
- F_R = cylinder force on retraction (lbs.)
- K = kinetic energy (inch lbs.)
- F_P = propelling force energy (inch lbs.)
- E_C = energy per cycle (inch lbs.)
- E_T = energy per hour (inch lbs. per hr.)
- W_E = effective weight (lbs.)
- B = cylinder bore (inches)
- R = cylinder rod dia. (inches)
- P = air pressure (psi)
- W_T = moving weight (lbs.)
- V = impact velocity (ft. per sec.)
- W = weight of load (lbs.)
- W_B = base weight (lbs.)
- W_A = guide rod adder (lbs.)
- C = cycles per hour

Compare the values in steps 4, 5 and 6 with the Shock Absorber Selection chart to determine the appropriate shock absorber for the application. Note: E_C and E_T values should not exceed the ratings listed in the Shock Absorber Selection chart.

SHOCK ABSORBER SELECTION				
BORE SIZE	SHOCK ABSORBER MODEL	W_E EFFECTIVE WT. (lbs.)	E_C ENERGY PER CYCLE (inch lbs.)	E_T ENERGY PER HOUR (inch lbs. per hr.)
1/2	1	2-22	150	300,000
1/2	2	20-200	150	300,000
3/4	1	2-22	150	300,000
3/4	2	20-200	150	300,000
1 1/8	3	3-18	300	400,000
1 1/8	4	10-60	300	400,000
1 1/8	5	30-180	300	400,000
1 1/2	6	17-100	650	600,000
1 1/2	7	50-300	650	600,000
1 1/2	8	150-900	650	600,000

MOVING WEIGHT VALUES			
BORE SIZE	BASE WT. (lbs.)	GUIDE ROD ADDER (lbs. per inch of stroke)	CYL. ROD DIA.
1/2	.407	.062	.250
3/4	.793	.112	.250
1 1/8	2.290	.250	.312
1 1/2	4.654	.446	.625

OPTIONS

SPECIFY AFTER STROKE:

- Internal cushions both ends HC
- Non-stock stroke powered slides (See page 8 for ordering information)
- Viton packing (available only on Series OPS for seal compatibility with certain fluids, consult factory for high temp. applications) Viton
- External bumpers and stop collars on retraction BR
- External bumpers and stop collars on extension BE
- External bumpers and stop collars on retraction and extension BB
- Magnetic Switches (available only on Series MPS) (See page 8 for ordering information)
- ACE Controls shock absorber on retraction SR (indicate appropriate shock absorber model)
- ACE Controls shock absorber on extension SE (indicate appropriate shock absorber model)
- ACE Controls shock absorber on retraction and extension SB (indicate appropriate shock absorber model)
- Special dimension "JJ" (tool block extension)* JJ = (indicate dimension required)

*Special dimension "JJ" plus stroke cannot exceed max. stroke available.
 Special dimension "JJ" plus stroke are considered "stroke" when determining load capability.

ORDERING INSTRUCTIONS

To order any products, specify information from categories listed below and arrange according to 'Example.'

	MPS	2	CR	1 1/2	X	6	HC	JJ=1" SE 7
Series	No. of Switches	Switch Model	Bore	Stroke	Internal Cushions "HC"	Special Options		
OPS	N/A	N/A	1/2, 3/4, 1 1/8	1/2" to 12"* (1/2" increments)	Bumpers Both Ends**	See Page 7 for Options		
			1 1/2	1" to 18"* (1" increments)	Fixed cushions Both ends**			
MPS	Qty.	43-CR 43-HP 43-HN	1/2, 3/4, 1 1/8	1/2" to 12"* (1/2" increments)	Bumpers Both Ends**			
		(Use suffix only)***	1 1/2	1" to 18"* (1" increments)	Fixed cushions Both ends**			

*1/2, 3/4 and 1 1/8 bore powered slides are available in 1/2" increments of stroke, 1/2" through 6". All others (up to 12" max.) are considered non-stock. 1 1/2 bore powered slides are available in even inch increments of stroke, 1" through 18", plus 1 1/2", 2 1/2" and 3 1/2" strokes. All others (up to 18" max.) are considered non-stock.

**1/2, 3/4 and 1 1/8 bore powered slides are available with internal urethane bumpers on both ends of the cylinder. Note: Internal bumpers add 1" to dimension "Y". 1 1/2 bore powered slides are available with internal "fixed" cushions on both ends of the cylinder and cylinder length is not affected.

***Switch models include: 43-CR (Reed), 43-HP (Hall Effect Sourcing) and 43-HN (Hall Effect Sinking). See also "Switch Options" in FLAIRLINE CYLINDERS AND VALVES CATALOG FL-32-C for specifications on switch models and mounting bands.

****The special options in the 'example' are special dimension "JJ" (tool block extension of 1") and ACE Controls shock absorber model "7" on "extension."

REPLACEMENT PARTS, PACKING KITS AND LUBRICANTS ARE AVAILABLE FOR ALL FLAIRLINE PRODUCTS

Flairline will not assume responsibility for the application of its products. Specifications and dimensions are subject to change without notice.

A flair for economy and availability.



23435 Industrial Park Drive Farmington Hills, MI 48335-2855 (248) 478-3330 Fax: (248) 478-3321
Website: www.flairline.com E-Mail: flairline@acecontrols.com