



1 1/16" BORE STAINLESS STEEL CYLINDER

SRR-17-□-□

Reverse Acting

Mount: Stud **Standard Stroke Lengths:** 1/2", 1", 1-1/2", 2", 3", 4"
Type: Rotating Rod **Spring Compressed:** 7 lbs. **Spring At Rest:** 2 lbs.
Options: M, B, W, V, N, H **Maximum Stroke:** 16" For M option add 0.125

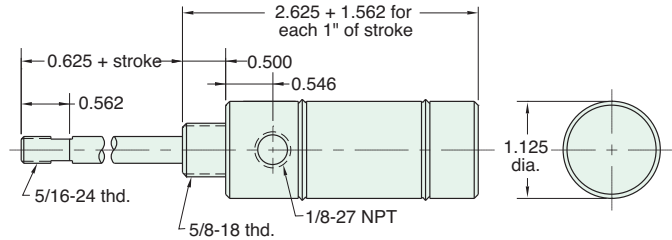

Nuts included, but not shown on drawing

URR-17-□-□

Reverse Acting

Mount: Universal **Standard Stroke Lengths:** 1/2", 1", 1-1/2", 2", 3", 4"
Type: Rotating Rod **Spring Compressed:** 7 lbs. **Spring At Rest:** 2 lbs.
Options: M, B, W, V, N, H, P2 **Maximum Stroke:** 16" For M option add 0.125

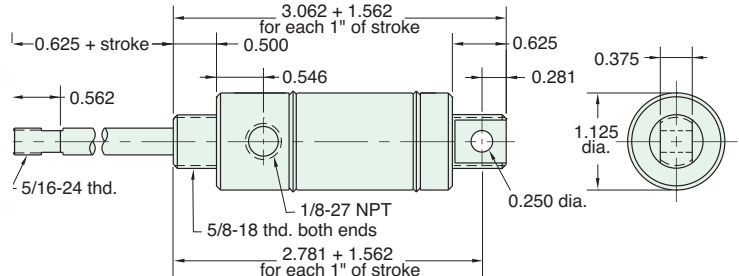

Furnished without nut(s). See Chart on Page 39.

SFD-17-□-□

Spring Bias

Mount: Stud **Standard Stroke Lengths:** 1/2", 1", 1-1/2", 2", 3", 4"
Type: Double Rod **Spring Compressed:** 7 lbs. **Spring At Rest:** 2 lbs.
Options: M, B, W, V, N, H, P6, P7, P8 **Maximum Stroke:** 15"

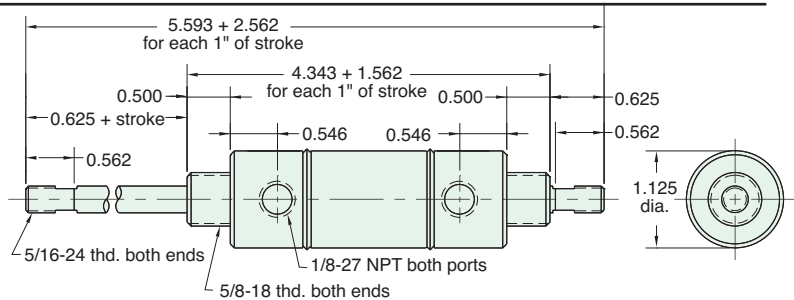

Nuts included, but not shown on drawing

SBR-17-□-□

Double Acting Rear Spring Bias

Mount: Stud **Standard Stroke Lengths:** 1/2", 1", 1-1/2", 2", 3", 4"
Type: Rotating Rod **Spring Compressed:** 7 lbs. **Spring At Rest:** 2 lbs.
Options: M, B, W, V, N, H, P6, P7, P8, S **Maximum Stroke:** 16" For S option add 0.250

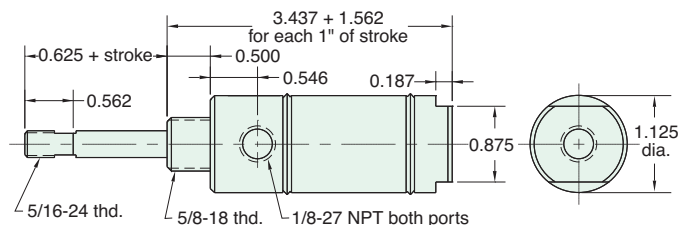

Nut included, but not shown on drawing