



# 3" BORE ACCESSORIES



## MOUNTING NUTS

### Stud Nut

Part Number	Across Flats	Nut Thickness	Nut (Thread)
<b><u>N24-12</u></b>	2 1/4"	1/2"	1 1/2-12

### Rod Nut

Part Number	Across Flats	Nut Thickness	Nut (Thread)
<b><u>N10-18</u></b>	15/16"	3/8"	5/8-18

## **CB-4895**

Clevis Bracket  
Material: Steel, bright zinc plated

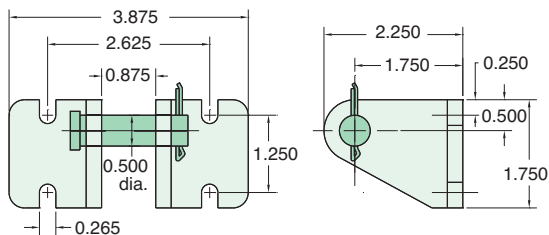

## **RK-4899**

Replaceable Rod Seal  
Material: aluminum body

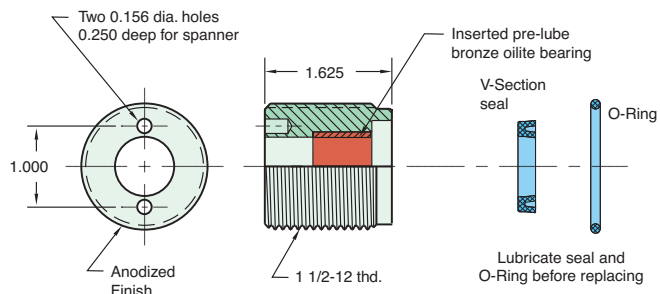

## **RC-4881**

Rod Clevis  
Material: Steel, electroless nickel plate

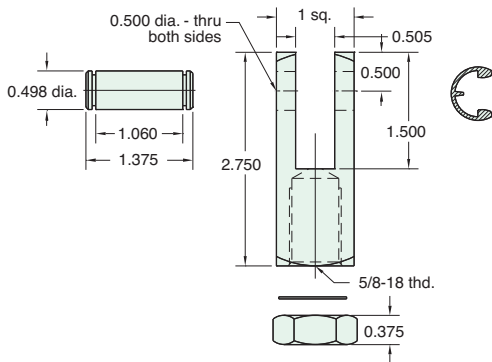

## **RE-4885**

Rod End  
Material: Steel, bright zinc plated body

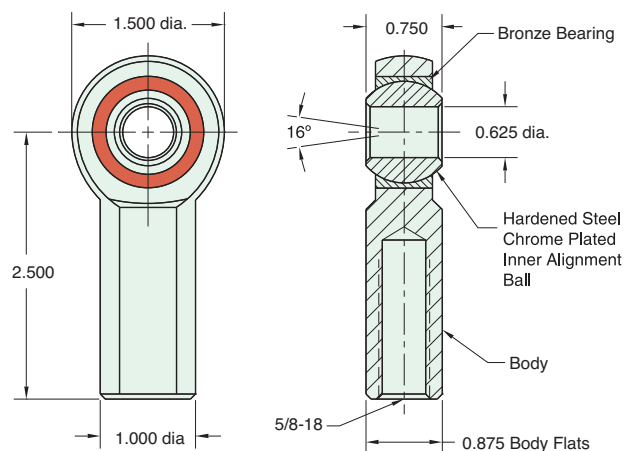

## **FB-4891**

Foot Bracket  
Material: Steel, bright zinc plated

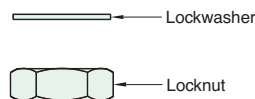
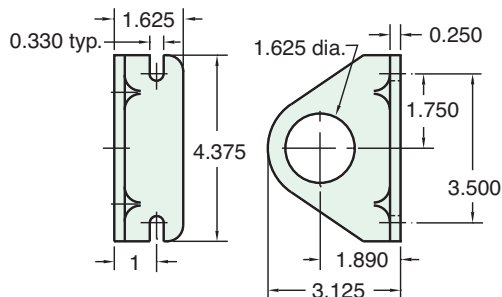

Max. Static Radial Load (rod end only): 7,400 lbs.  
Fits Rod Thread Size: 5/8-18