

# NEW! 1 1/6" BORE ALL STAINLESS STEEL CYLINDER



## SS-SDR-17-□-□

Double Acting



**Mount:** Stud      **Standard Stroke Lengths:** 1/2", 1", 1-1/2", 2", 3", 4", 5", 6"  
**Type:** Rotating Rod      **Maximum Stroke:** 12"  
**Options:** V, M, N, TG

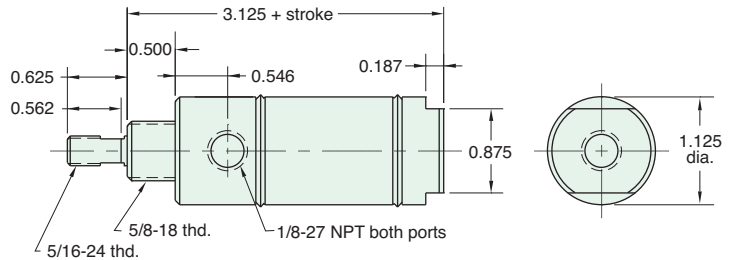

Nut included, but not shown on drawing

## SS-UDR-17-□-□

Double Acting



**Mount:** Universal      **Standard Stroke Lengths:** 1/2", 1", 1-1/2", 2", 3", 4", 5", 6", 8", 10", 12"  
**Type:** Rotating Rod      **Maximum Stroke:** 24"  
**Options:** V, M, N, TG

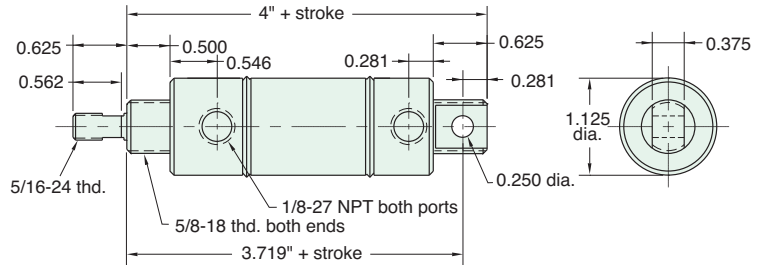

Furnished without nut(s). See Chart below.

## SS-SDD-17-□-□

Double Acting



**Mount:** Stud      **Standard Stroke Lengths:** 1", 2", 3", 4", 5", 6"  
**Type:** Double Rod      **Maximum Stroke:** 6"  
**Options:** V, M, N, TG

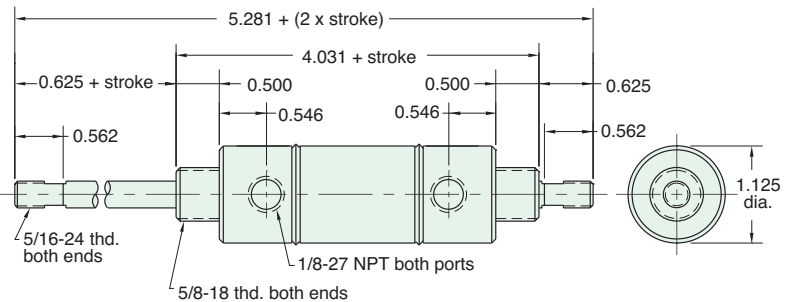

Nuts included, but not shown on drawing

## ACCESSORIES

### Mounting Nuts

Part Number	Nut Type	Across Flats	Nut Thickness	Nut (Thread)
<b>N10-18-SS</b>	Stud	15/16"	3/8"	5/8-18
<b>N05-24-SS</b>	Rod	1/2"	3/16"	5/16-24

Part Number	Product	Drawing Shown on Page
<b>RC-1781-SS</b>	Rod Clevis	39
<b>FB-1791-SS</b>	Foot Bracket	39
<b>CB-1795-SS</b>	Clevis Bracket	39