

# L20/L25

## Side Mounted CPVC Plastic Liquid Level Switch

### OVERVIEW

The Whitman Controls L20/L25 Series Side Mounted CPVC Plastic Liquid Level Switches are typically used in water and potable water applications. The side mount provides added versatility, allowing the switch to be used as a high or low level indicator, and plastic body provides use up to 100 PSI. These are most often used in many O.E.M. and various other custom industrial applications. These are available with several options as specified by the user.

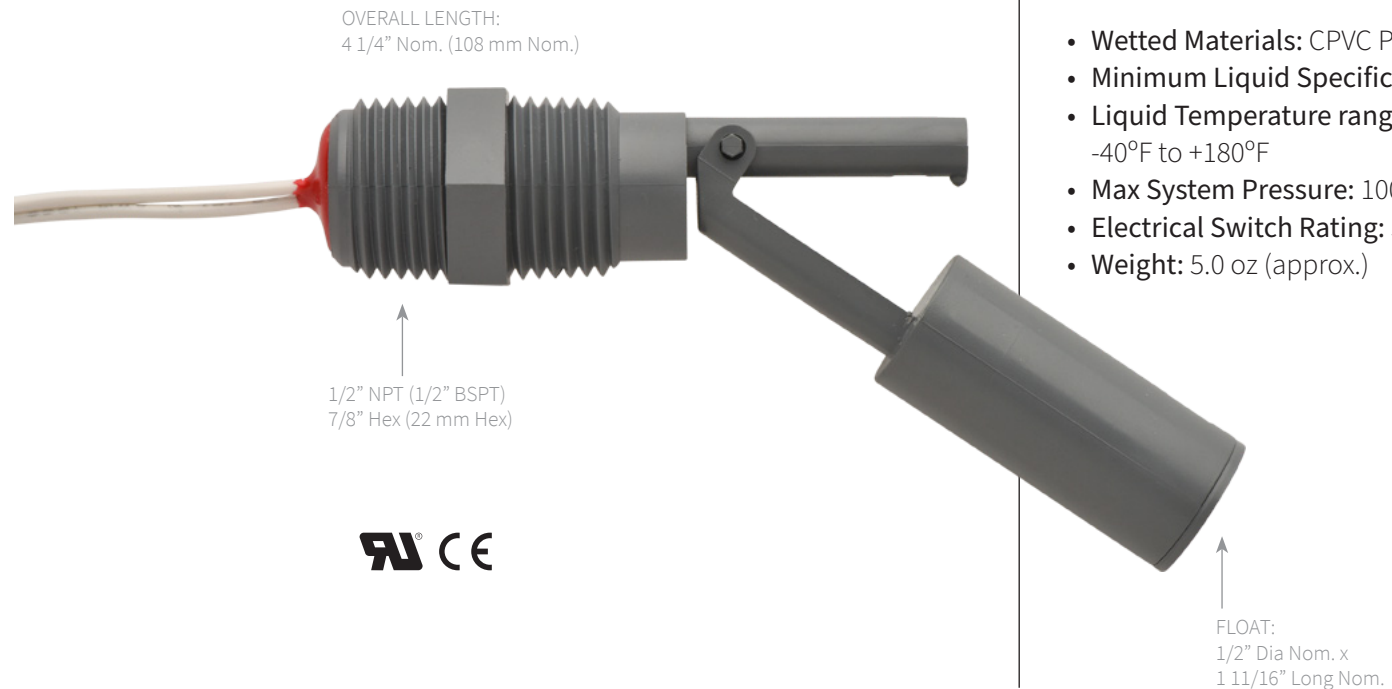

### KEY FEATURES

- Red Seal potting submersible to a NEMA 6 rating
- CPVC Plastic
- Side mounted
- Extensive operating temperature range
- SPST availability

### SPECIFICATIONS

- **Wetted Materials:** CPVC Plastic
- **Minimum Liquid Specific Gravity:** 0.90
- **Liquid Temperature range:** -40°F to +180°F
- **Max System Pressure:** 100 PSIG
- **Electrical Switch Rating:** 50 VA
- **Weight:** 5.0 oz (approx.)

### PERFORMANCE CHARACTERISTICS

	L20 Series	L25 Series
Fitting	1/2" NPT	1/2" BSPT
Wetted Materials	CPVC	CPVC
Electrical Switch Rating	50 VA	50 VA
Temperature Range	-40°F to +180°F	-40°C to +82°C
Minimum Liquid Specific Gravity	0.90	0.90
Crush Pressure	100 PSI	7 BAR
Lead Wires	20 AWG 24" PVC	20 AWG 600mm PVC
Part Number	L20-16-S1-16-NO	L25-16-S1-16-NO

\*Actuation point is roughly midway of float travel in liquid with a specific gravity of approximately 1.0  
 CAUTION: Customer Media and environment must be compatible with construction materials as outlined above